

IQDAVM

Video and Audio Monitoring Encoder

The IQDAVM accepts a serial 4:2:2 input to provide up to four equalized and re-clocked outputs, three monitoring composite outputs and four embedded audio analog outputs. On-screen audio 'confidence' displays of four embedded audio channels are provided on the -M version.

Does this module suit your application?

- Up to four re-clocked serial 4:2:2 outputs
- Three monitoring composite PAL/NTSC/PAL-N outputs
- Four analog audio outputs or 2 stereo pairs
- Balanced audio output level adjustable +12 dBu to +24 dBu for 0 dB FS input (-D version)
- Unbalanced audio output level adjustable 1 Volt pk-pk to 4.5 Volts pk-pk into >50 k ohm, for 0 dB FS input (-B version)
- Audio selection from any embedded channel pair
- 20-bit digital-to-analog audio conversion, -95 dB THD+N typical (Full Scale)
- Audio polarity invert
- Embedded audio presence indication
- On screen display of audio level and status (-M versions only)
- Non-audio ancillary data presence indication
- EDH error detection and reporting

- Test signal generator (Color Bars/Black and – 20 dBFS Tone/Silence)
- Automatic 525/625 line detection and no valid signal indication
- Card edge and RollCall remote control

Why should you choose this module?

- The on-screen monitoring function of the four audio channels is via familiar bar-graph displays. By using a combination of color bands and text a large amount of information may be conveniently viewed via the composite video monitoring output
- Balanced audio output level adjustable +12 dBu to +24 dBu for 0 dB FS input (-D version)
- Unbalanced audio output level adjustable 1 Volt pk-pk to 5 Volts pk-pk in to 1 k ohm, for 0 dB FS input (-B version)
- 20-bit digital-to-analog conversion, -95 dB THD+N typical (Full Scale)

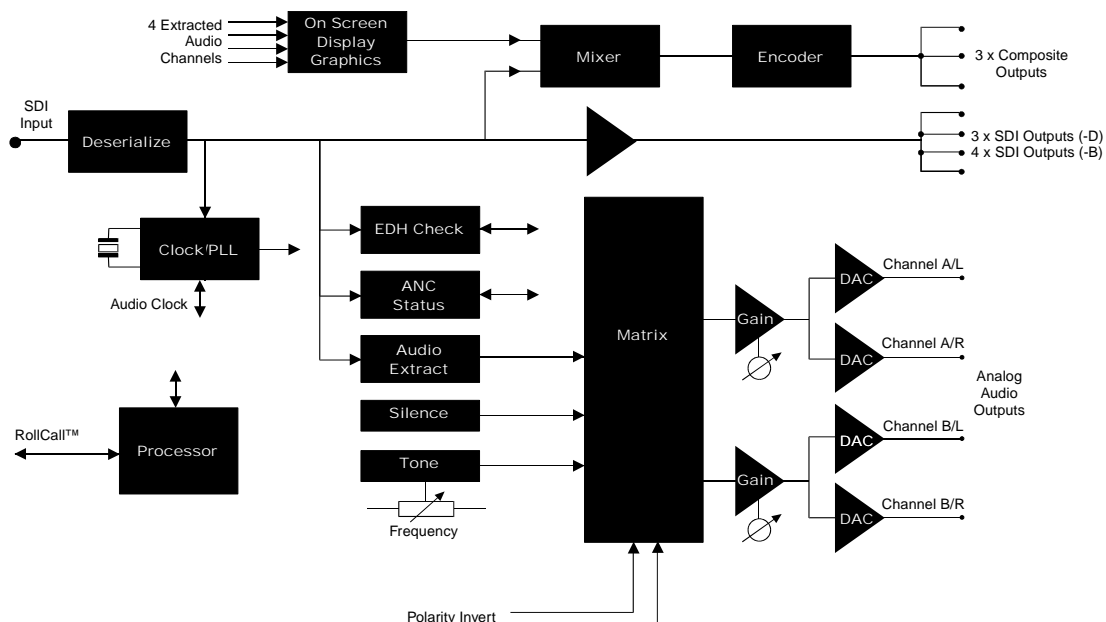

IQDAVM

Video and Audio Monitoring Encoder

Order codes for IQH3A/1A enclosures

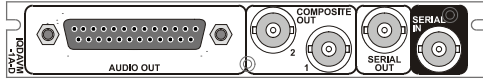

IQDAVM-1A-D Audio & Video Monitoring Encoder. Balanced Audio.

IQDAVM-1A-D-M Audio & Video Monitoring Encoder with on-screen display. Balanced Audio.

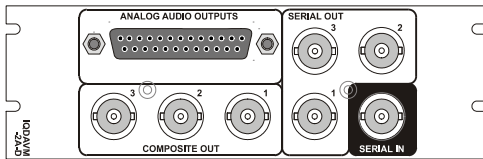

IQDAVM-2A-D Audio & Video Monitoring Encoder. Balanced Audio.

IQDAVM-2A-D-M Audio & Video Monitoring Encoder with on-screen display. Balanced Audio.

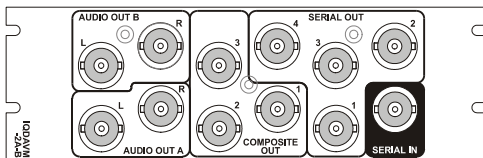

IQDAVM-2A-B Audio & Video Monitoring Encoder. Unbalanced Audio.

Order codes for other enclosures

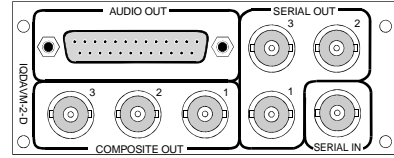

IQDAVM-2-D Audio & Video Monitoring Encoder. Balanced Audio.

IQDAVM-2-D-M Audio & Video Monitoring Encoder with on-screen display. Balanced Audio.

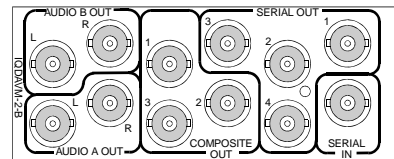

IQDAVM-2-B Audio & Video Monitoring Encoder. Unbalanced Audio.

For more details on enclosure types please refer to the Frames/Enclosures section

Inputs & Outputs

Signal Inputs

Serial Digital 1 x SDI via BNC connector
Standards..... SMPTE 259M-C-1997, SMPTE 272M-A-1994

Signal Outputs

Serial Digital 4 (-B version) 3 (-D version) x SDI via BNC connectors
Standards..... SMPTE 259M-C-1997, SMPTE 272M-A-1994
Composite Video 3 at standard level via BNC connectors
Standards..... PAL/NTSC/PAL-N
Analog Audio 2 Stereo pairs Balanced via 25 way (-D version, broadcast level) or unbalanced via BNC (-B versions, low level)

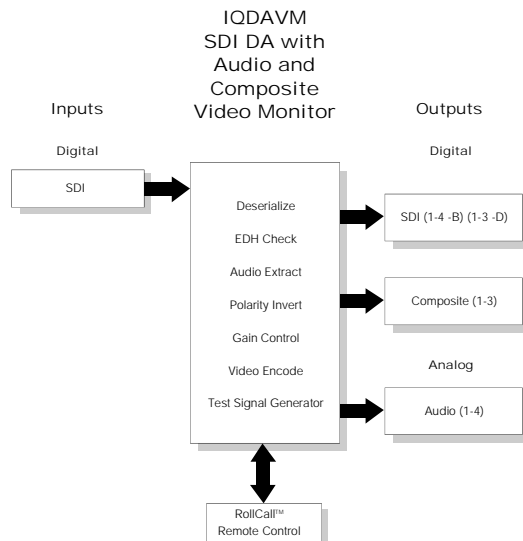

IQDAVM

Video and Audio Monitoring Encoder

Card Edge & RollCall Controls

Card Edge Controls (also available via RollCall)

OSD Audio Monitoring.....	On/Off (-M versions only)
OSD Text	On/Off (-M versions only)
Pattern	Color Bars Pattern On, off
Standard	Line standard = 625: PAL/PAL-N Line standard = 525: NTSC
Pedestal	On/Off (NTSC Only)
Local	Local/Remote Control
EDH Reset	Resets error flags
Audio Channel Select	Any Embedded Channel Pair

Indicators

Power O.K.	
Input Loss	
Audio presence	On selected pairs
EDH	Present; Error-Minute: Error-Hour

Functions Available via RollCall Only

Headroom (-D)	Adjustable from +12 to +24 dB
---------------------	-------------------------------

Level (-B)	Adjustable from 1.0 V to 4.5 V pk-pk
------------------	---

Analog Output Gain A/B	Adjustable ± 6 dB in 0.2 dB steps
------------------------------	---------------------------------------

Display Information

Default pattern selection	Color Bars or black (Default used on input loss)
---------------------------------	--

Default audio selection.....	Tone or silence (Default used on extraction fail or input loss)
------------------------------	---

Polarity	Invert polarity of extracted audio pair
----------------	---

Logging	Input Loss; Input Line Standard; EDH error. Presence of extracted audio, low-level audio and silence.
---------------	---

Standard detection	Auto 525/625 line rate detection
--------------------------	----------------------------------

Audio Gain control.....	Independent for each output pair
-------------------------	----------------------------------

Chroma bandwidth	1.6 MHz or 2 MHz
------------------------	------------------

Pedestal	On, off (NTSC only)
----------------	---------------------

Non-audio HANC data.....	Presence indication
--------------------------	---------------------

Specifications

SDI Input Return Loss	Better than -15 dB at 270 MHz
Input Cable Length.....	> 200 m of PSF1/2
SDI Output Return Loss	Better than -15 dB at 270 MHz
Composite Video Output	1 V pk-pk into 75 ohm (EBU Bars)
Internal Processing	8-bit composite encoding with 9-bit oversampled DAC's

Video Signal

Luminance Frequency Response	0 – 4 MHz +0.1 dB, -0.5 dB
Chrominance Frequency Response	1.6 MHz or 2 MHz (selectable) - 6 dB
Video Signal/Noise Ratio	Better than - 68 dB (weighted – flat field) Better than -62 dB (weighted – ramp)
Differential phase.....	< 2°
Differential gain.....	< 1 %
Processing Delay.....	approx. 2 μ s

Audio Signal

THD+N at 24 dBu	Better than -80 dB (0 dBFS, 1 kHz)
Linear Freq. Response	+0.1 dB , - 0.3 dB (20 Hz to 20 kHz w.r.t. 1kHz)
Conversion	20-bit
Sampling	48 kHz Synchronous to D1 video stream
Dynamic Range.....	Better than 100 dB (Balanced)
Dynamic Range	Better than 98 dB (Unbalanced)
Output Level (Balanced)	Level Adjustable +12 dBu to +24 dBu, $\pm 5\%$
Output Level (Unbalanced) ..	Adjustable 1 V pk-pk to 4.5 V pk-pk into >50 k ohm, for 0 dB FS input, $\pm 5\%$
Output Impedance (Balanced)	25 ohm Nominal
Output Impedance (Unbalanced)	75 ohm Nominal

Power Consumption

Module Power Consumption	8.5 W max (balanced versions) 6.5 W max (unbalanced versions)
--------------------------	--