

# IQMDA00

## HD/SD-SDI Monitoring Distribution Amplifier

The IQMDA00 is an HD/SD-SDI distribution amplifier and HD-SDI monitoring downconverter. This module takes HD-SDI streams and produces four re-clocked HD-SDI outputs. It also converts the input signal to same frame-rate SD-SDI outputs for monitoring. Output options include 4 x HD-SDI and 3 x SD-SDI. One group of audio can also be carried through from the HD inputs to the SD outputs. This module can also be used to distribute SD-SDI signals to SMPTE 259M-C, providing 7 outputs from one input.

### Does this module suit your application?

- An HD-SDI monitoring down-converter to allow compact low-cost, low-power monitoring solutions for HD environments
- Standards supported:
  - HD-SDI to SMPTE292M
  - SD-SDI to SMPTE259M-C
- A distribution amplifier for HD-SDI signals with SD-SDI monitoring capability
- A distribution amplifier for SD-SDI signals with 7 x SD-SDI outputs
- Audio capability means that a complete Audio/Video monitoring solution is possible
- Supports one output group of embedded audio channels with input audio group selection
- Monitoring output aspect ratio may be set to letterbox, anamorphic or center cut out picture modes
- Signal loss detection
- Maintains the input frame-rate for the output signal
- RollCall remote control and monitoring compatible

### Why should you choose this module?

- Extremely compact solution for downconversion of HD picture sources for monitoring on SD equipment with embedded audio
- Allows low cost SD video monitors with SDI inputs to be used to monitor HD signals
- Allows HD sources to be recorded on SD recording equipment for monitoring or viewing at a future time
- Combined audio and video support means that SD monitoring systems can be used for HD feeds including their audio content
- SD/HD input flexibility allows distribution of SD-SDI signals or distribution and downconversion of HD-SDI signals without the need for separate hardware
- Will pass SD signals to allow monitoring of either HD or SD signals fed via a single connector

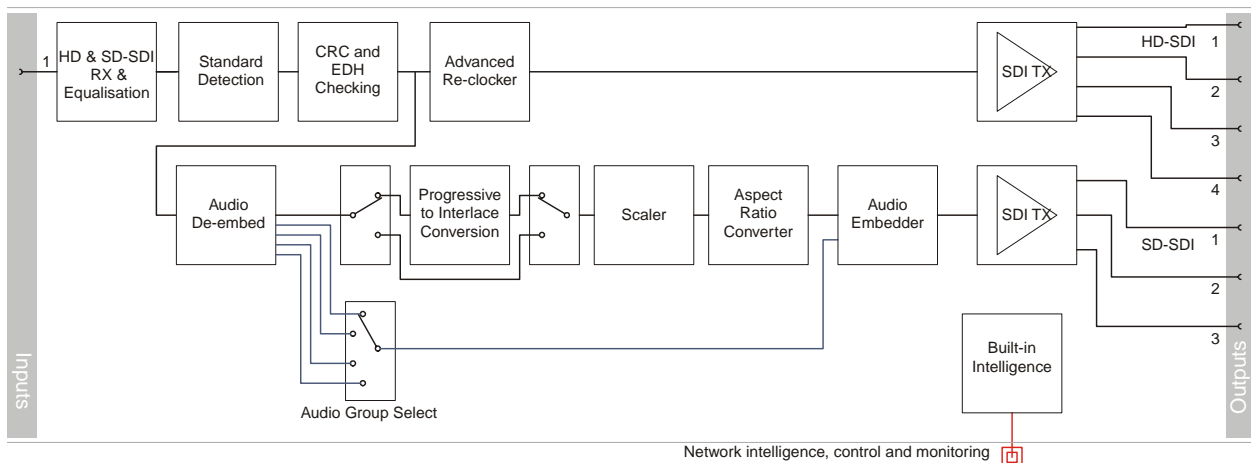

### Order codes for IQH3A/1A enclosures

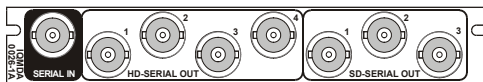

IQMDA0026-1A HD/SD-SDI DA and HD-SDI Monitoring Down-converter. 4 HD-SDI and 3 SD-SDI outputs

For more details on enclosure types please refer to the Frames/Enclosures section

# IQMDA00

## HD/SD-SDI Monitoring Distribution Amplifier

---

### Inputs & Outputs

#### Signal Input

Electrical ..... 1.5 Gbit/s HD-SDI, SMPTE 292M  
270 Mbit/s SDI, SMPTE 259M-C

Connector / Format ..... BNC/ 75 Ohm panel jack on  
standard S&W connector panel

Input Cable Length ..... Up to 140 m Belden 1694A @  
1.5 Gbit/s  
Up to 350 m Belden 1694A @  
270 Mbit/s

Return loss ..... > -15 dB

#### Distribution Outputs

Electrical ..... 1.5 Gbit/s HD-SDI, SMPTE 292M  
270 Mbit/s SDI, SMPTE 259M-C

Connector / Format ..... BNC/ 75 Ohm panel jack on  
standard S&W connector panel

Outputs ..... 4

Return loss ..... > -15 dB

#### Downconverter Outputs

Electrical ..... 270 Mb/s SD-SDI SMPTE 259M-C  
including one group of embedded  
audio

Connector / Format ..... BNC/ 75ohm panel jack on  
standard S&W connector panel

Outputs ..... 3

Output Return Loss ..... > -15 dB

---

### Card Edge & RollCall Controls

#### Indicators

Power ..... OK

CPU ..... OK

Status ..... OK (Green)  
Warning (Yellow)  
Error (Red)

#### Available Conversions

Input	Output
1125(1080)/29.97i or sF	525(483)/29.97i
1125(1080)/25i or sF	625(576)/25i
750(720)/59.94P	525(483)/29.97i
750(720)/50P	625(576)/25i
625(576)/25i	625(576)/25i
525(483)/29.97i	525(483)/29.97i

#### RollCall Control

Control ..... SD Output standard (including  
auto)

Aspect ratio for monitoring outputs

letterbox, anamorphic, center cut  
out

User Memories ..... 16 x Save / Recall / Rename

Input audio group selection.. Groups 1 to 4

Reporting ..... Input format(including unknown),  
input loss, CRC error

Logging ..... Input Status  
Input Standard  
Convert  
CRC/EDH  
CRC/EDH total

RollTrack Controls ..... On/Off, Index, Source, Address,  
Command, Status, Sending.

RollTrack Outputs ..... Unused  
SD Output Video Delay  
Input Present  
Input Loss

---

### Specifications

Processing ..... 10 bit

Under/over shoot ..... <10%

Linearity .....  $\pm 1$  LSB

S/N ..... > 65 dB

Color Space ..... Transmission matrix conversion  
from SMPTE274 to ITUR-601

Y/C delay ..... < 10 ns

SD Output Delay ..... 1 output Frame  
625(576)/25i = 40 ms  
525(483)/29.97i = 33 ms  
No conversion = 0 ms  
With SD inputs = 1.2  $\mu$ s

Horizontal Response (anamorphic)

$\pm 0.2$  dB to 5.4 MHz, > 45 dB stop  
band attenuation

Vertical Response ..... > 40 dB stop band attenuation

#### Power Consumption

Module Power Consumption  
8.5 W Max